

# IRP10212S-10 2U Din Rail Installation Manual



## Included in this package

(2) 2U Side Panel

(1) 2U Center Panel with Din Rail installed

(1) PVC Wire Duct

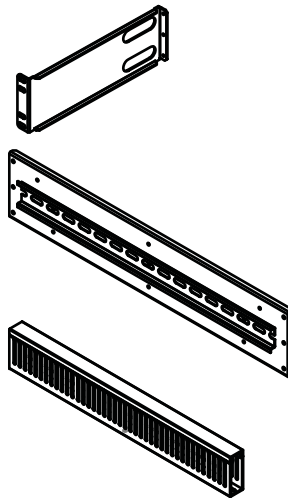

(9) M4 x 6 Pan Head Screw



(4) #10-32 x 5/8 Rack Screw



(4) #12-24 x 5/8 Rack Screw



## Installation Steps

1. Place 2U Side Panel on right side and left side of 2U Rear Panel.

2. Align (3) mounting holes on rear of 2U Side Panel with (3) threaded holes on left side of 2U Center Panel. Secure panel with (3) M4 x 6 screws. (Figure 1) .

3. Align (3) mounting holes on rear of 2U Side Panel with (3) threaded holes on right side of 2U Center Panel. Secure panel with (3) M4 x 6 screws.

4. Remove cover on PVC Wire Duct then align perforiated holes on PVC with (3) threaded holes on rear of center panel.

5. Secure PVC Wire Duct with (3) M4 x 6 screws. (Figure 2)

6. Installation complete.

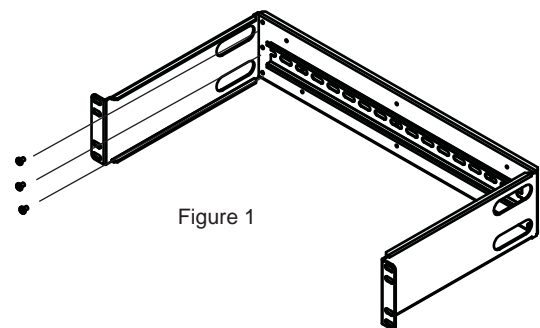

Figure 1

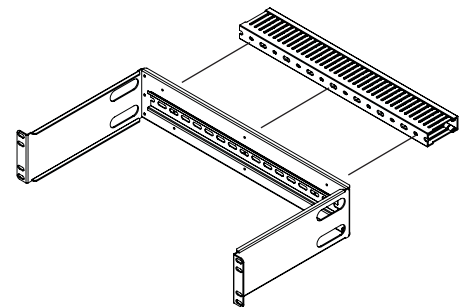

Figure 2.

